

KINESIS™

THE ORIGINAL MOVEMENT



www.technogym.com



A vast desert landscape with rolling sand dunes under a clear blue sky. The dunes are golden-brown and have soft shadows cast across them, suggesting a low sun. The sky is a uniform, clear blue. The overall scene is serene and open.

“Kinesis™ is born out of the need to bring people closer to physical activity to improve the quality of their life. The inspiring principle is to rediscover the beauty of movement by means of free and natural movements”

Technogym's Study and Research Centre

PEOPLE LOOK FOR RESULTS AND

ENGAGING EXPERIENCES



Most people are aware that their health and quality of life can be enhanced by physical activity. They will choose to increase physical activity when they believe it will provide the benefits they seek in a way that feels inspiring to them. New ways of conditioning the body that will inspire joy in movement, confidence and more satisfying ways of living will be the key to reaching these people. They need to be attracted and retained by a stimulating experience that will guarantee:

physiological benefits

- *Improved strength*
- *Improved articulatory flexibility*
- *Improved dexterity*

better quality of life

- *Improved efficiency in daily activities*
- *Improved knowledge and awareness of the body*
- *Improved stress management*

KINESIS™

INNOVATION
MOVEMENT,



We sought MOVEMENT for inspiration, putting the human being in the best condition possible to make use of space.

We sought NATURE for inspiration, recreating the interaction of shapes and colours in a space where the human being and human sensations are at the centre of everything.

We sought Science for inspiration, developing a technology which creates resistance for tri dimensional movements.

A child is running on a beach at sunset, flying a blue kite. The kite has a long green tail that is blowing in the wind. The child is wearing a red top and a patterned dress. The sky is a mix of blue and orange, and the ocean waves are visible in the background.

IS BORN OUT OF
NATURE, SCIENCE

KINESIS™ REDISCOVERS

THE OBJECTIVE:
to recapture movement
at its most natural



Thanks to technological progress mankind has made incredible steps forward, but has forgone natural habits. Consequences such as obesity and the diseases of a sedentary life style threaten our well being.

It is imperative to go back to the origins of movement, when survival depended upon physical and mental prowess, and recover the ability to move and to deal more effectively with everyday life.

© The Economist Newspaper Limited, London
13-12-2003

The front cover of an important international periodical highlighting the obesity problem.



Past

Present

THE ORIGINS OF MOVEMENT



KINESIS™ MOVES THE MIND A

THE OBJECTIVE:
to re-establish the correct
balance between mind
and body, improving
the quality of life.

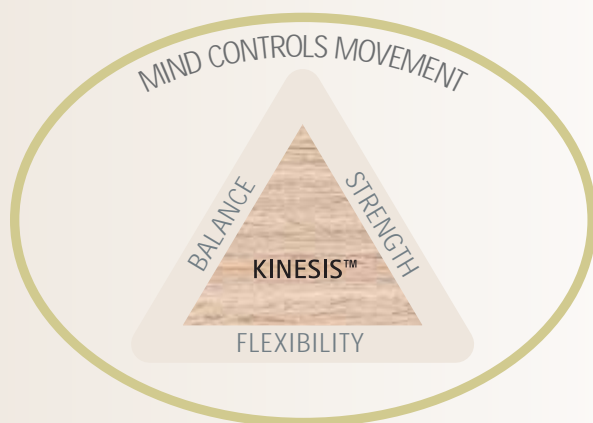

MIND

With Kinesis the mind guides the body in a natural way,
in a tri dimensional space (3D).

BALANCE

The ability to actively maintain the body in balance, making use of the stabilising muscles during each movement.

FLEXIBILITY

The ability to move freely through a full range of motion.

STRENGTH

The ability to work with resistance, either using one's own body or an external weight.



ND THE BODY

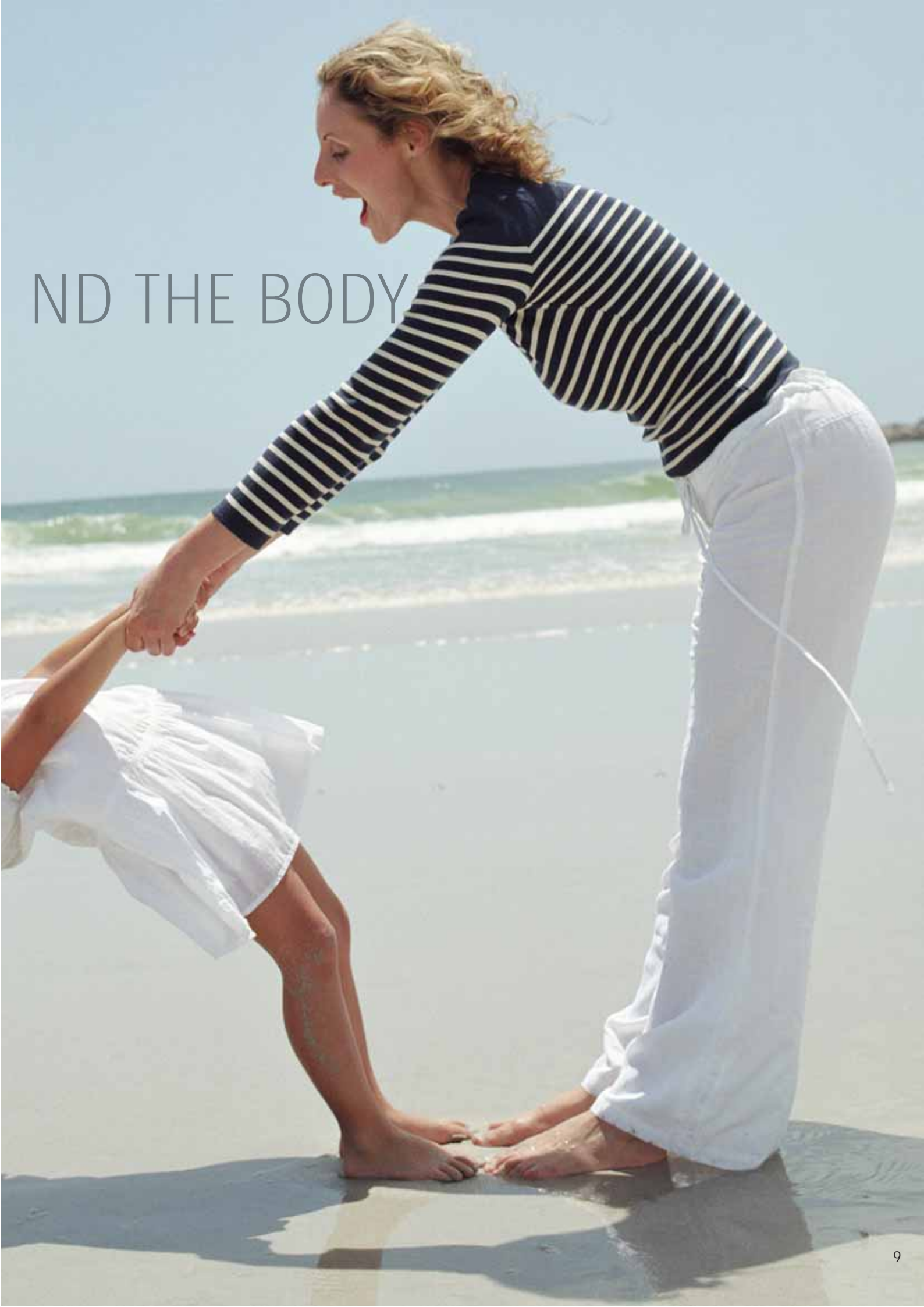

KINESIS™ PLACES THE HUMAN TECHNOLOGY

THE OBJECTIVE:
to re-establish
the centrality
of the individual

With Kinesis™, body and mind are required to interact with the environment and the space in which the person moves. The person is at the center of an intimate space with strong echoes of nature. Kinesis™ introduces a high-touch concept where the person is at the center stage and technology behind the scenes.



A close-up photograph of a person's hand reaching out to touch tall, green grass in a field. The background is a bright blue sky with some light clouds. The hand is positioned in the center-right of the frame, with fingers slightly spread. The grass is in sharp focus, while the background is blurred.

BEING AT THE CENTRE STAGE,
BEHIND THE SCENES.

KINESIS™
IS A NEW EXPERIENCE
IN A NEW SPACE



KINESIS™

THE ORIGINAL MOVEMENT





INCREASING RESISTANCE

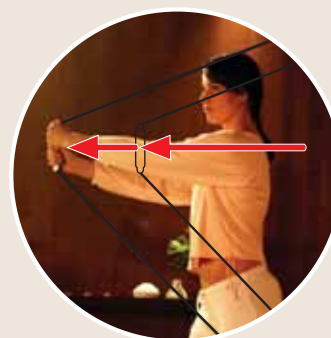

FullGravity™ patent pending Technology allows for resistance to vary in accordance with the increase in width of the movement. Kinesis™ activates the kinetic chains, not only the single muscle.

DOUBLE WEIGHT STACK



Each cable controls a single weight stack which is therefore independent from the other. This solution allows greater freedom in exercise definition and resistance selection.

WALL



CLOSED LOOP CABLE SYSTEM



A patented continuous cable loop system connects with each cable handle. The design allows you to move freely with minimal interference with the body especially in thrust movements.

MINIMAL REGULATIONS



For greater ease of use, the handle is always ready for use and does not require any adjustment to modify its position.

KINESIS™ IS A TRI DIMENSIONAL MOVEMENT

With Kinesis™ movement is natural and enjoyable. Kinesis™ allows movements to be easy and natural, without restrictions.



FULLGRAVITY™ TECHNOLOGY (Patent Pending)

Kinesis™ "FullGravity™ Technology", a patent pending innovation allows you to keep resistance in tri dimensional movements.

3D PULLEY SYSTEM (Patent Pending)

Kinesis™ incorporates a patent pending 360° Rotating Pulley system which enables movement on three planes. The system allows the user to move freely without cable interference.

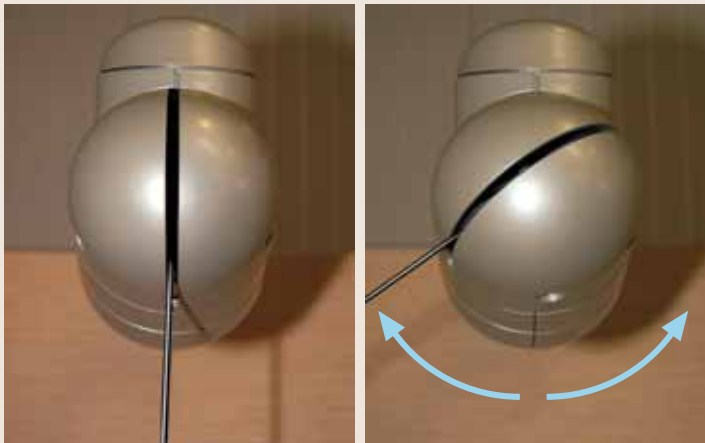

KINESIS™ WALL (Patent Pending)

Technogym® has dedicated particular care to design and furnishing, creating the "Kinesis™ Wall" (patent pending) with a unique design and look that epitomises the "Kinesis" space.





KINESIS™ IS A NEW TRAINING METHOD

Kinesis™ allows over 250 exercises and movements to improve strength, flexibility and balance.



With Kinesis™ it is possible to perform exercises that involve a specific group of muscles, at variable levels of difficulty, to train strength only or to promote flexibility and balance as well. Furthermore, Kinesis™ allows the completion of movements that involve several groups of muscles on different planes, thus integrating strength, flexibility and balance training. Routines are the combinations of exercises and movements in one fluid performance.

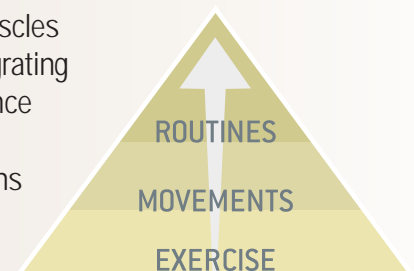





KINESIS™ IS A RELAXING ENVIRONMENT IN A NEW SPACE

Kinesis™ is mind and body movement in a context that helps achieve inner balance and harmony of the body in space.



The environment in which to train is essential. The Kinesis™ space has been envisioned as an intimate and natural place where one can feel at ease, to facilitate relaxation and concentration. Interior design contributes to creating the suitable atmosphere of wellbeing and self collection to stimulate natural and free movement. The design follows a modular concept by which it is possible to choose between different types of solutions suited to different spaces and experiences.





KINESIS™ IS A NEW BUSINESS OPPORTUNITY



BENEFITS FOR THE CLUB OWNER

- Attract new clients that do not attend the gym
- Offer new forms of exercise
- Optimise space
- Increase business opportunities

BENEFITS FOR THE PERSONAL TRAINER

- Offer a new training method
- Widen client pool
- Offer infinite variety of personalised movements/exercises
- Benefit from on-going training

BENEFITS FOR THE END USER

- Achieve tangible results
- Train in a new space
- Regain precision and elegance of movement
- Train in a stimulating and non repetitive way



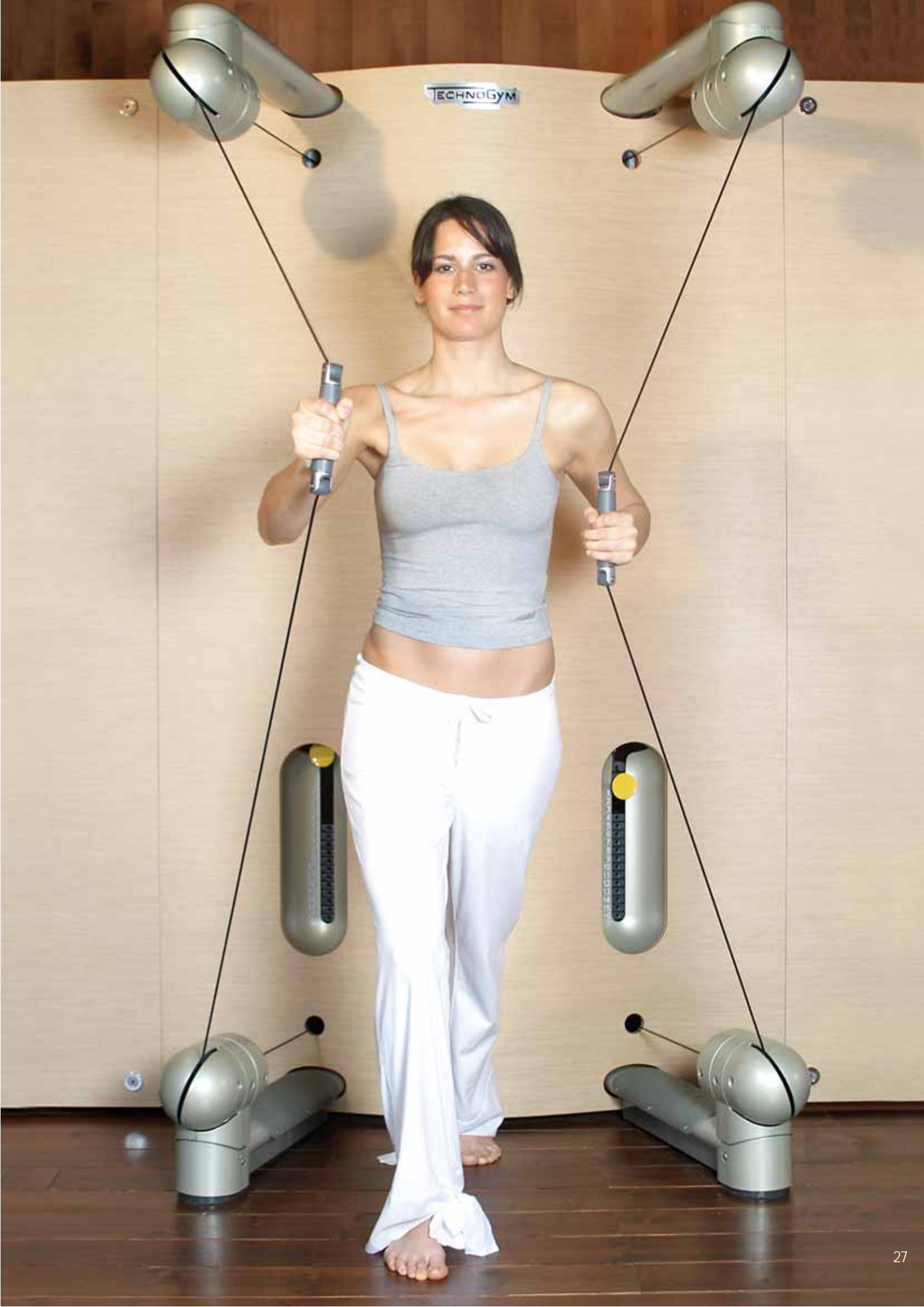

TECHNOGYM



KINESIS™ IS MULTIMEDIA FRIENDLY

Kinesis improves the relationship between clients and trainer thanks to innovative technological support integrated in the Kinesis Wall.



PERSONAL KINESIS™ SOFTWARE:

The PDA program, with its easy and intuitive use, allows trainers to create, view and modify specific programmes for each of their clients.

Thanks to the film library, it can be used to show and teach the movements, exercises and routines.

KINESIS™ VISUAL LEARNING:

The software program for the PC integrated in the Kinesis™ Wall aids learning and allows users to visualise the exercises, movements and routines.

It is the ideal tool for training with Kinesis™: the Touch Screen integrated with Kinesis™ Software for Visual Learning allows an easy consultation and visualisation of the exercises, movements and routines at any time during a Kinesis session.



Kinesis™ is compatible and integrated with the Wellness System.



KINESIS™



EXERCISES

Exercises for main muscle groups in order of difficulty. The exercises work a specific muscle group at a time.



MOVEMENTS

Movements for the anterior kinetic chain, posterior kinetic chain and core muscle. Movements require a good body control and stability.



PROGRAMMES

Groups of exercises and movements for a specific purpose. The programmes are arranged into different difficulty levels.



KINESIS™ INNOVATIVE APPROACH TO INTERIOR DESIGN

OAK



wood colour option

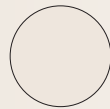

Arm and finishing details colour

WENGE



wood colour option



Arm and finishing details colour



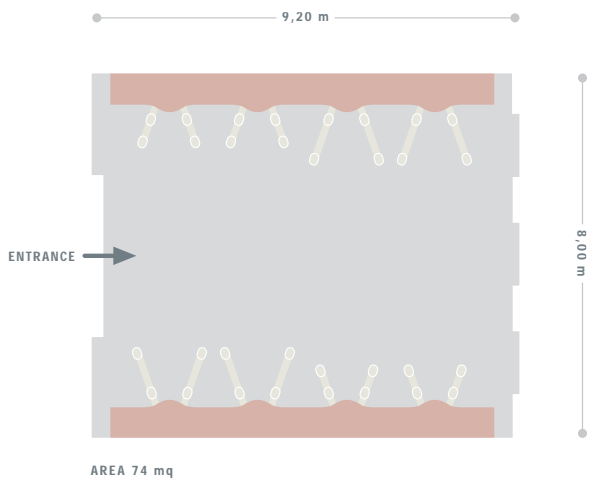

KINESIS™ MAKES GOOD USE OF SPACE

Kinesis™ makes it possible to reconvert existing and inappropriately used spaces, which currently have a low return of investment into prestigious and profitable spaces.

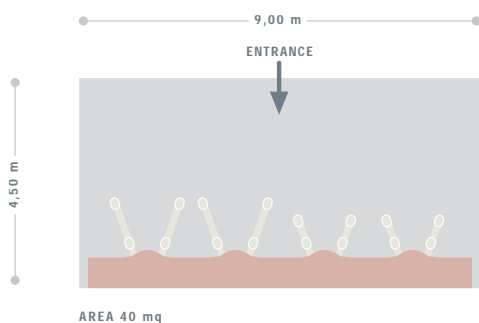
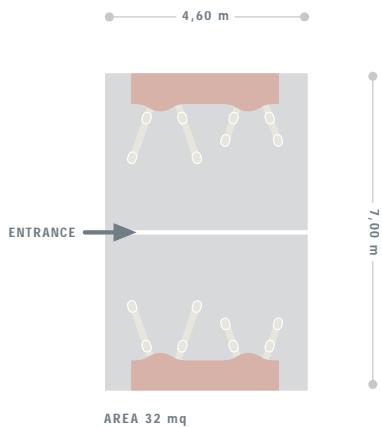

Kinesis™ allows the club to offer its clients an engaging experience whilst at the same time achieving high levels of return of investment, high profile status and increased customer retention. Kinesis™ equips the club with a high prestige program as well as a practical solution to improve the profitability of space inside the club.

Squash and raquetball courts, a small course room, an office; scarcely used rooms are ideal for housing the Kinesis™ Space, thus making the best use of available resources.

BEFORE



Squash court

AFTER



New Kinesis™ Space

KINESIS™ LAYOUT

A 4 MODULES AGAINST THE WALL IN LINE + 2 EXTERNAL PANELS

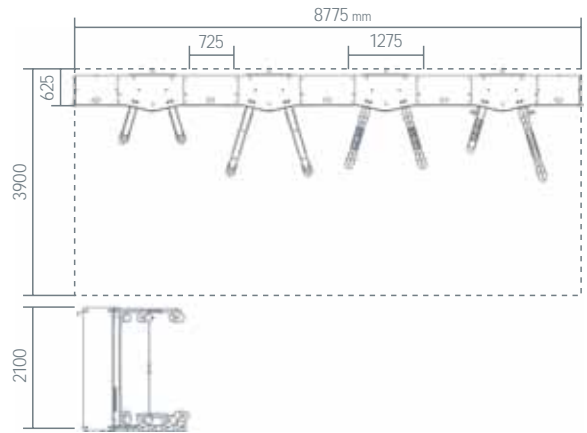
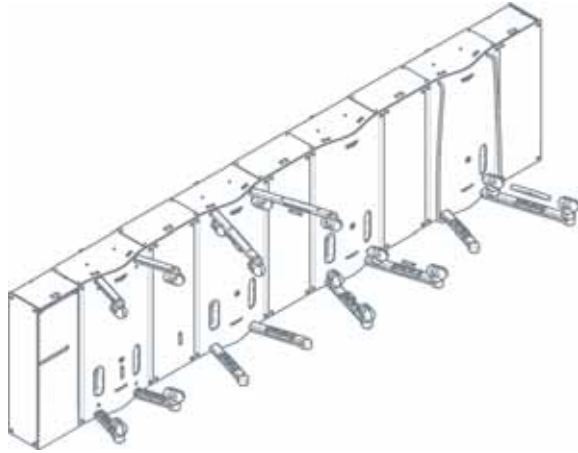

B 2 & 2 OPPOSITE MODULES AGAINST WALL

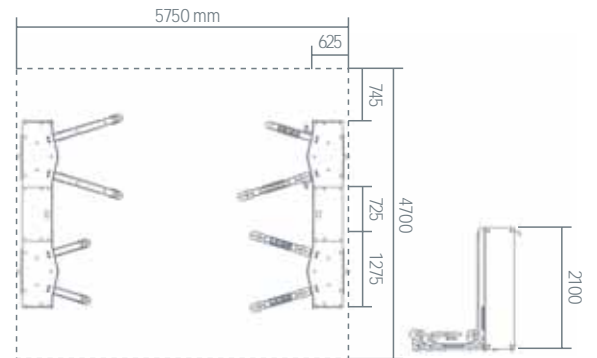
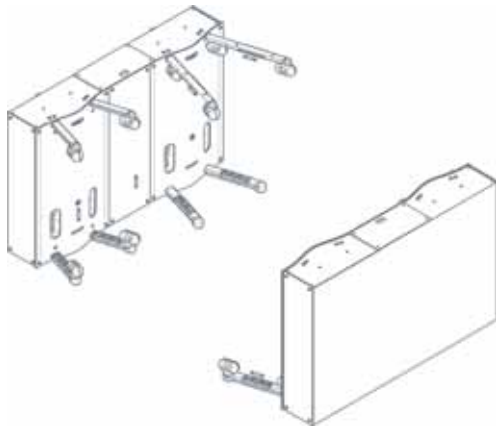

C 4 MODULES IN LINE WITH POSTERIOR SHIELD

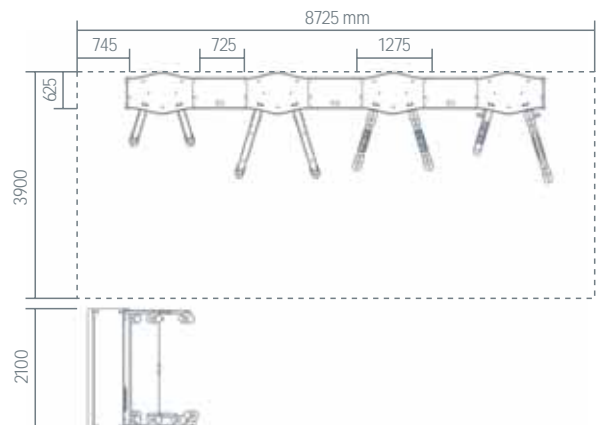
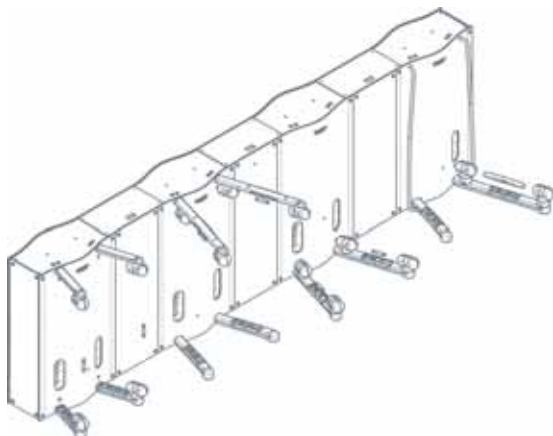

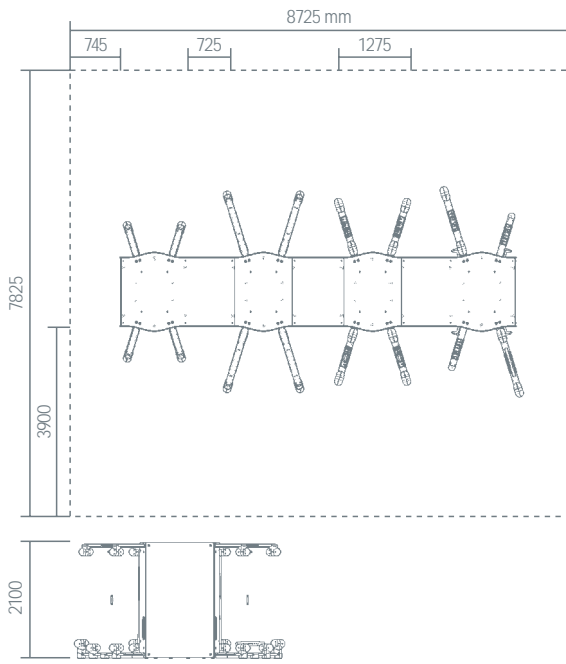

4 & 4 MODULES BACK TO BACK

D

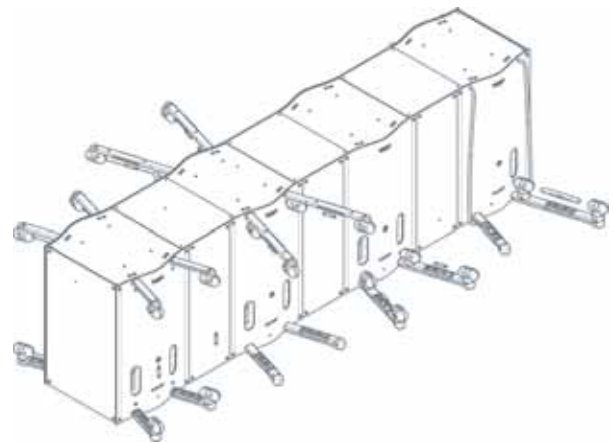

4 MODULES AGAINST THE WALL IN LINE

E

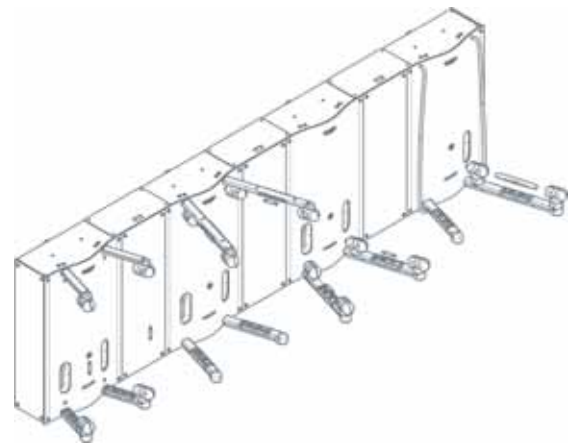
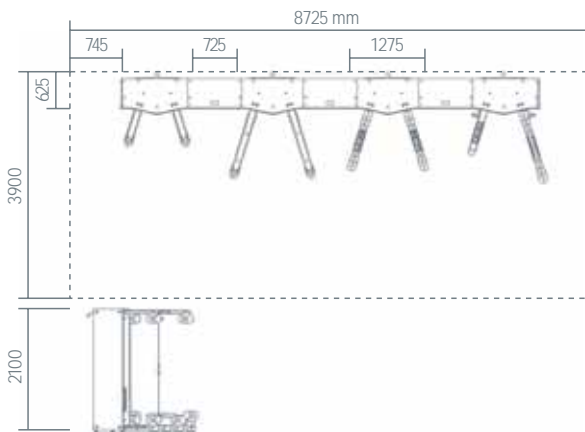

4 MODULES IN LINE AGAINST WALL WITH ANGULAR PANEL

F

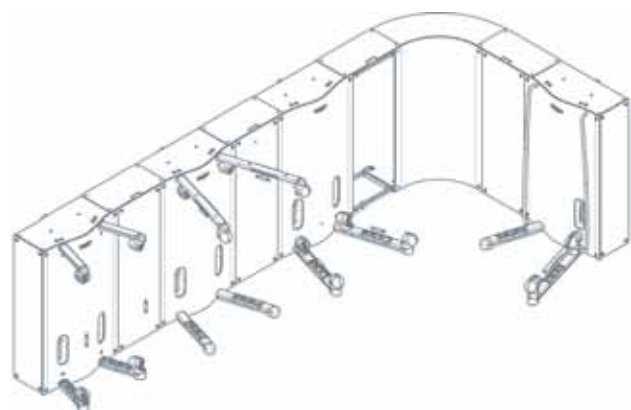
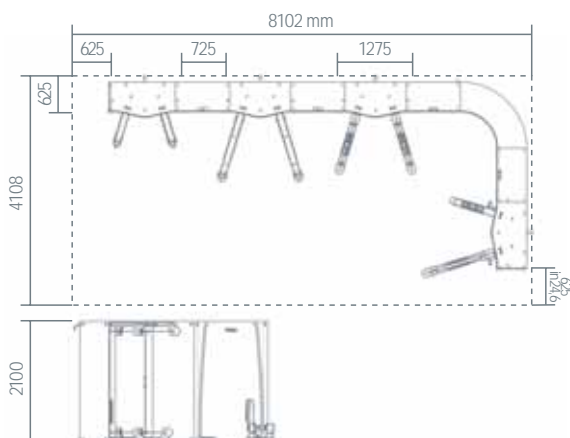

Cod. X174

WOOD STRIPS

Cod. M5550
+ A0000204AA

ALPHA



Cod. M5650
+ A0000207AA

BETA



Cod. A0000201AA

ANTERIOR
CONNECTION PANEL
WITH TOWEL HOLDER

Cod. A0000210AA

ANTERIOR CONNECTION
PANEL WITH INTEGRATED
PC TOUCH SCREEN

Cod. A0000202AA

ANTERIOR CONNECTION
PANEL WITH SHELF

KINESIS™ SPACE MODULES

Cod. M5600
+ A0000206AA



GAMMA

Cod. A0000197AA
+ A0000223AA

ANTERIOR FLAT
CONNECTION
PANEL BASIC

Cod. M5700
+ A0000205AA



DELTA

Cod. A0000234AA

CONNECTION
ANGULAR PANEL

Cod. A0000197AA

ANTERIOR FLAT CONNECTION
PANEL BASIC

Cod. A0000266AA

ACCESSORIES
CABINET

The picture above is for show purpose only, it is not a layout option.

KINESIS™ ACCESSORIES



Cod. A035
ROTATING HANDGRIP



Cod. A0000254AA
ANKLE BRACELET



Cod. A0000253AA
UNIVERSAL KINESIS™
LOCK



Cod. A0000255AA
DOUBLE LOOP
HANDLE



Cod. A0000242AA
KINESIS™ BELT



Cod. A0000269AA
FOAM ROLLER



Cod. A0000260AA (cm 55 diameter)
Cod. A0000261AA (cm 65 diameter)
Cod. A0000267AA (Wellness ball hoop)

WELLNESS BALL



Cod. A0000270AA
STRETCHING MAT



Cod. A0000213AA
ROCKER BOARD



Cod. A0000250AA
KINESIS™ BENCH



Cod. A0000214AA
WOBBLE BOARD



Cod. A0000268AA
FOAM MAT

**ITALY**

TECHNOGYM SpA
Via Giorgio Perticari, 20
47035 GAMBETTOLA (FC)
Tel. +39 0547 56047
Fax +39 0547 650505
E-mail: informazioni@technogym.com

GERMANY

TECHNOGYM Wellness & Biomedical GmbH
Im Geisbaum 10
63329 EGELSBACH
Ph. +49 6103 201240
Fax +49 6103 2012410
E-mail: info.d@technogym.com

U.S.A.

TECHNOGYM USA Corp.
830 Fourth Avenue South - Suite 300
SEATTLE WA 98134
Ph. +1 206 6231488
Toll free: 800 8040952
Fax +1 206 6231898
E-mail: info@technogymusa.com

UNITED KINGDOM

TECHNOGYM UK LTD.
Doncastle House
Doncastle Road - Bracknell
BERKSHIRE RG12 8PE
Ph. +44 1344 300236
Fax +44 1344 300238
E-mail: UK.info@technogym.com

BENELUX

TECHNOGYM BENELUX B.V.
Rijijnsvoor 259
2901 LB Capelle a/d IJssel
Ph. +31 10 4223222
Fax +31 10 4222568
E-mail: info@technogym.nl

FRANCE

TECHNOGYM FRANCE SAS
4, Rue Nieuport B.P. N.109
78143 VELIZY CEDEX
Ph. +33 1 34582585
Fax +33 1 34582588
E-mail: info@technogym.fr

SPAIN

TECHNOGYM TRADING S.A.
Parque de negocios Mas Blau
Ed. Océano 1 c/Garrotxa, 10-12 Bajos 3^a
08820 El Prat de Llobregat, Barcelona
Ph. +34 902 101 093
Fax +34 933 704 736
E-mail: informacion@technogym.net

PORTUGAL

TECHNOGYM TRADING S.A.
Parque das Nações - Edifício Smart - R. Pólo Norte,
Lt.1.06.1.1 - Piso 1 - Fracção 1F
1990-075 Lisboa
Ph. +351 218 934 030
Fax +351 218 942 026
E-mail: informacao@technogym.net

JAPAN

TECHNOGYM JAPAN Ltd
Zip code: 105-0011
2-10-1 Sumitomo Fudosan Shibazono building 6F
Shiba Koen, Minato-ku, Tokyo, Japan
Ph. +81 3 6402 7788
Fax +81 3 6402 7789
E-mail: info@technogym.co.jp

CHINA

TECHNOGYM (Shanghai) INTERNATIONAL TRADING Co., Ltd.
Room 3001, China Insurance Building, No. 166, East Lu
Jia Zui Road, Pudong, Shanghai, China
Ph. +86 21 5888 6355
Fax +86 21 5888 6950
E-mail: sales_china@technogym.com

ASIA

TECHNOGYM ASIA Ltd
18/F, Unit 2
59 Connaught Road, Central - Hong Kong
Ph. +852 3 1162 622
Fax +852 3 1162 625
E-mail: sales@technogymasia.com

OTHER COUNTRIES

TECHNOGYM SpA
Via Giorgio Perticari, 20
47035 GAMBETTOLA (FC) ITALY
Tel. +39 0547 650500
Fax +39 0547 650591
E-mail: info@technogym.com